



400 Series TPED Cylinder Valves

Applications

High Flow cylinder valves for high-pressure Hydrogen tube trailers and bulk gas cylinder storage stacks.

Suitable for Hydrogen. Check with Oasis for compatibility with other gases.



TH404 (SAE and Medium Pressure)

Materials

Item	Part	Material
1	Body & Cap	Stainless Steel
2	Ball	Stainless Steel
3	Stem	Stainless Steel
4	Seats	PEEK
5	Thrust washer	POM

Item	Part	Material
6	Gland	POM
7	O-rings	FKM
8	Backup rings	NBR
9	Handle	Stainless Steel
10	Adaptor	Stainless Steel

Product Information

Type Tested to ISO23826.

Complies with TPED 2010/35/EU.

All products are manufactured to ISO 9001 standards.

1 1/2-12 male cylinder thread.

MP threads to Maximator Document 3999.1831.

SAE threads conform to SAE J1926-1.

Custom handles available on request

End user shall consider the pressure and flow of the system to which the valves are installed.

Features & Benefits

All materials are suitable for use in Hydrogen applications.

Easy to service, kits readily available.

Quarter turn handle - easy to tell when the valve is in open or closed position.

Anti blow-out stem design.

Includes a 3/8" cone and thread live PRD port.

Manufactured from certified bar stock.

Lockout system available to prevent accidental operation of valve.

3/8" SAE O-Ring (9/16-18 UNF) commissioning port.

The commissioning port allows the cylinder to be isolated for testing.

Fully indexable adjustment, eliminating the need to "clock" cylinders.

TPRD available for supply with valve. Refer to Oasis for options.



400 Series TPED Cylinder Valves

Medium Pressure (Cone and Thread) Product Specification

Part Code	Mass lb (kg)	Minimum Operating Pressure bar (psi) *	Working Pressure (WP) bar (psi) **	MAWP (PS) bar (psi) ***	Min. Temp. °F (°C)	Max Temp. °F (°C)	Time Before Rekit [^]	Stem Open Torque ft-lb (Nm) ^{^^}	Cv	Service Kit
TH404-66BA8R0-G000	6.6 (3.0)	6.9 (100)	520 (7539)	650 (9424)	-40 (-40)	185 (85)	5 Years	14.7 (20)	1.2	TH404-SK1

- * Lowest settled gas pressure for which the ball valve is designed. This is the minimum pressure that the product will hold constant bubble tight seal.
- ** Settled pressure of a compressed gas at a uniform reference temperature of 15°C in a full pressure receptacle for which the valve is intended. : TPED valves are tested as per ISO 23826 which requires test pressure of 1.2xWP
- *** : Some valves have a derated PS/MAWP to align with end connection type/size.
- [^] The service life stated depend on the system conditions and may not be achievable in all situations.
Contact Oasis for further information.
- ^{^^} Maximum opening torque at maximum operating pressure.

SAE Product Specification

Part Code	Mass lb (kg)	Minimum Operating Pressure bar (psi) *	Working Pressure (WP) bar (psi) **	MAWP (PS) bar (psi) ***	Min. Temp. °F (°C)	Max Temp. °F (°C)	Time Before Rekit [^]	Stem Open Torque ft-lb (Nm) ^{^^}	Cv	Service Kit
TH404-62BA8R0-G000	6.6 (3.0)	6.9 (100)	520 (7539)	650 (9424)	-40 (-40)	185 (85)	5 Years	14.7 (20)	4.9	TH404-SK2

- * Lowest settled gas pressure for which the ball valve is designed. This is the minimum pressure that the product will hold constant bubble tight seal.
- ** Settled pressure of a compressed gas at a uniform reference temperature of 15°C in a full pressure receptacle for which the valve is intended.
- *** Minimum pressure applied to the valve during testing.
- [^] The service life stated depend on the system conditions and may not be achievable in all situations.
Contact Oasis for further information.
- ^{^^} Maximum opening torque at maximum operating pressure.



400 Series TPED Cylinder Valves

Dimensions - Inch (mm)

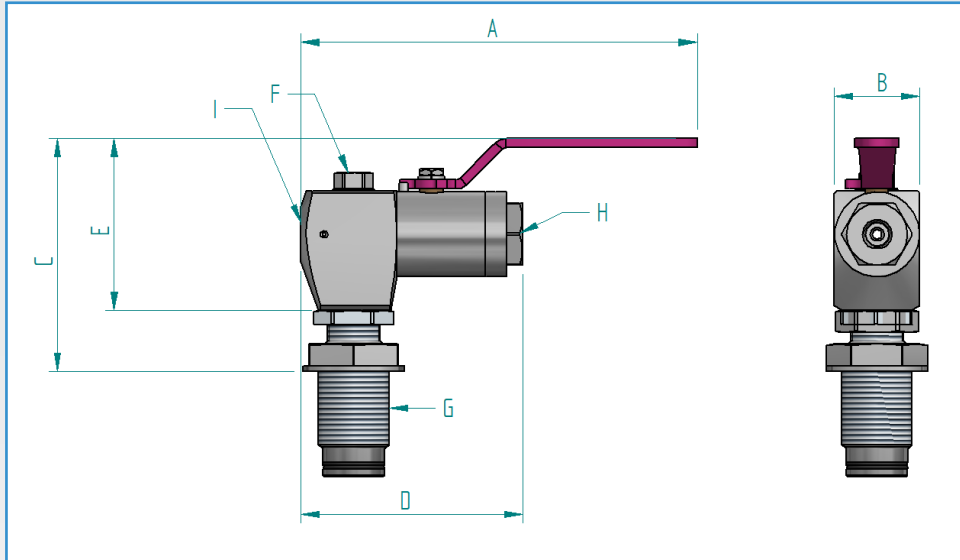

Part Code	A	B	C	D	E
TH404-66BA8R0-G000	8.4" (214mm)	1.8" (46mm)	5.0" (126mm)	4.7" (120mm)	3.6" (92mm)
TH404-62BA8R0-G000					

Connection Specifications

Part Code	F COMMISSIONING PORT (SUPPLIED WITH HD PLUG)	G MALE CYLINDER THREAD	H FEMALE END CAP THREAD	I (PRD/LIVE PORT) FEMALE THREAD
TH404-66BA8R0-G000	9/16"-18 UNF (3/8" SAE)	1 1/2" UNF male bore seal	9/16"-18 UNF (3/8" MP)	9/16"-18 UNF (3/8" MP)
TH404-62BA8R0-G000			1/2" SAE (3/4-16 UNF- 2B)	



400 Series TPED Cylinder Valves

Accessories:

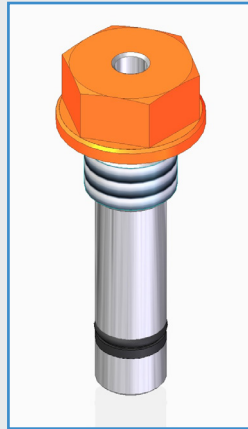

TH404-010 Commissioning Plug

Features & Benefits

Manufactured from certified bar stock.

Allows the cylinder to be isolated for testing.

Can be powder coated to your custom safety colour.

Part Code	SAE Thread Size	Mass Oz (g)	Material	Hex size	Min. Operating Pressure bar (psi)*	Max. Operating Pressure bar (psi)**	Min. Temp. °F (°C)	Max Temp. °F (°C)	Service Kit
TH404-010	3/8"	2.2 (60)	Stainless Steel	19 mm	6.9 (100)	650 (9424)	-40 (-40)	185 (85)	TH404-010-SK1

* Minimum pressure that the product will hold constant bubble tight seal.

** Maximum pressure that the product will hold constant bubble tight seal.

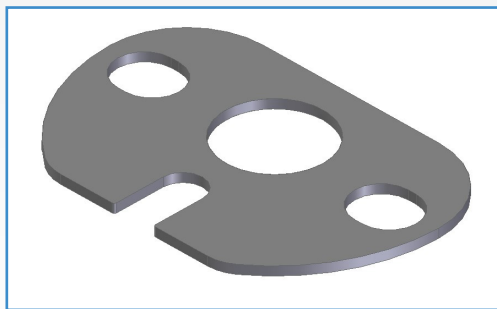

TH404 Lockout Plate

Features & Benefits

Prevents accidental opening or closing of the valve.

Part Code	Material
XTH404-012	Stainless Steel