



HC308

Ultra-Fast Fill Quick Coupler

Instruction Manual

▲ WARNING

Failure to follow these instructions or to properly install and maintain this equipment could result in gas leakage, fire or explosion causing property damage and personal injury or death.

Oasis products must be installed, operated and maintained by trained and competent personnel in accordance with all applicable local codes, rules and regulations in addition to the Oasis Instructions.

Oasis Engineering Ltd. will not be held liable in such circumstances where installation, operation and maintenance procedures were performed by incompetent personnel resulting in improper assembly, unsafe operation, equipment damage or personal injury.

Oasis recommends that all service technicians should watch the Product Servicing Video before attempting to service this part.



Servicing Video

Oasis Engineering Ltd
129 Birch Avenue, Tauranga, New Zealand.
T: +64 7 928 3808
E: info@oasisNGV.com
W: www.OasisNGV.com



Instruction Manual

Warning!

High pressure gas and gas equipment can cause serious harm to both infrastructure and personnel if safety precautions are not followed.

Oasis recommends considering the use of the following PPE when working with high pressure along with any other site specific health and safety requirements:



Foot Protection



Hearing Protection



Safety Helmets



Hand Protection



Safety Glasses



Ensure the system is clean of debris, vented and isolated before any installation or servicing work is carried out.

To help with coupling in cold conditions



Interflon Fin Super (Aerosol) or a similar product

If coupler is hard to uncouple due to cold temperature icing, spray both male & female coupling faces with Interflon Fin Super (aerosol) or a similar product to help with ease of uncoupling in cold conditions.

Tools Required

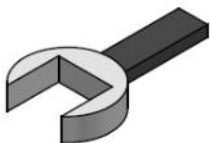

Spanner (Wrenches)

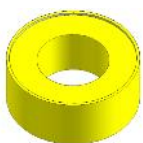

Yellow, Gas Rated, PTFE Thread Tape

- AW TITASEAL
- McMaster-Carr High-Density Thread Sealant Tape
- Blue-Monster gas-guard
- Or Similar



Spray bottle (Snoop or soapy water)



Anaerobic Thread Sealant with PTFE (Optional)

- Loctite 567
- Swagelok SWAK
- Herson Dripstop 940
- Gasoila FasSeal-ATS
- Or Similar

1. Apply thread tape and thread sealant.

Please ensure that the tape covers all threads, but does not overlap the end of the fitting

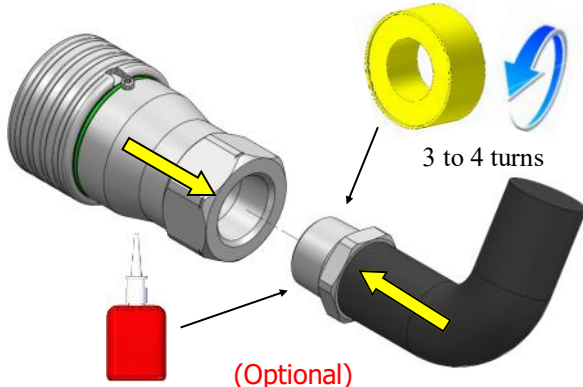

(Optional)
If galling is a concern or unable to cover all threads, apply a light coating over thread tape and uncovered threads.

2. Join and tighten the connection.

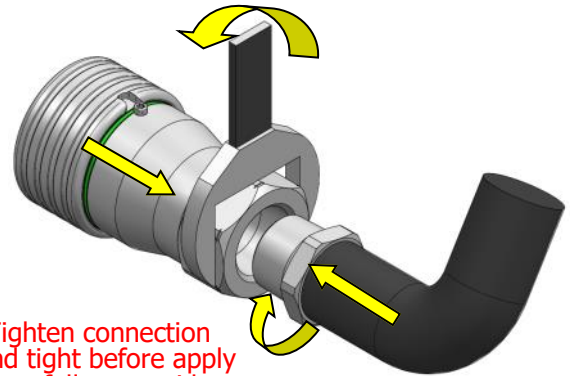

Tighten connection hand tight before apply two full turns with wrench

3. Complete.

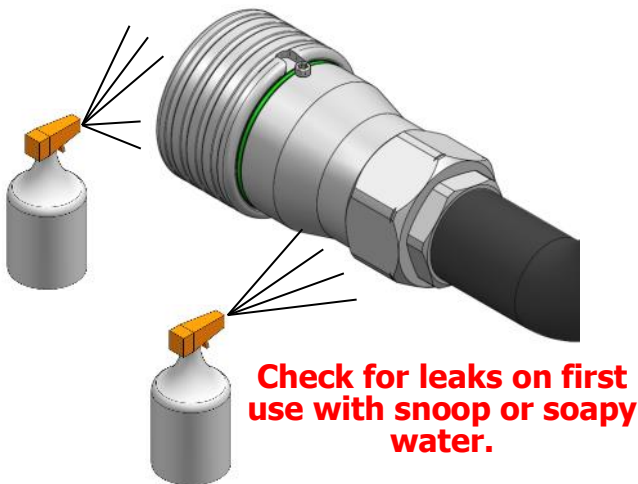

Check for leaks on first use with snoop or soapy water.

4. Apply thread tape and thread sealant.

Please ensure that the tape covers all threads, but does not overlap the end of the fitting

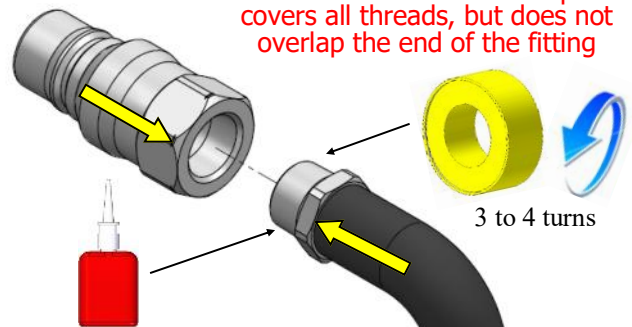

(Optional)
If galling is a concern or unable to cover all threads, apply a light coating over thread tape and uncovered threads.

5. Place dust cap over fitting. Join and tighten the connection.
Ensure it does not cross thread.

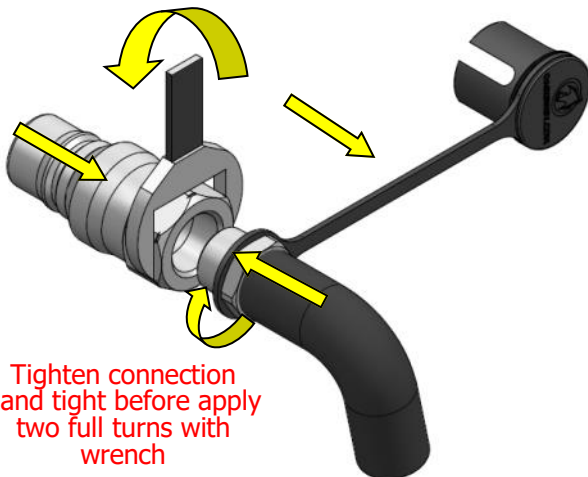

Tighten connection hand tight before apply two full turns with wrench

6. Complete. Put dust cap over male end when uncoupled.



Check for leaks on first use with snoop or soapy water.

1. Align notch in sleeve with locating screw.

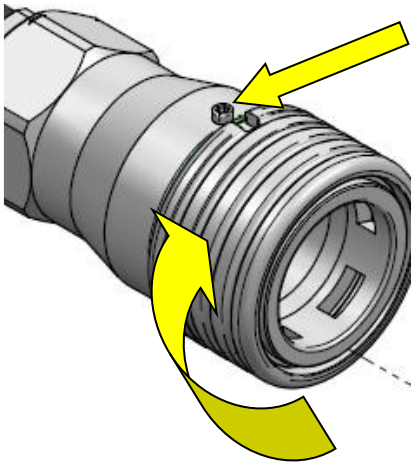

2. Pull back sleeve.

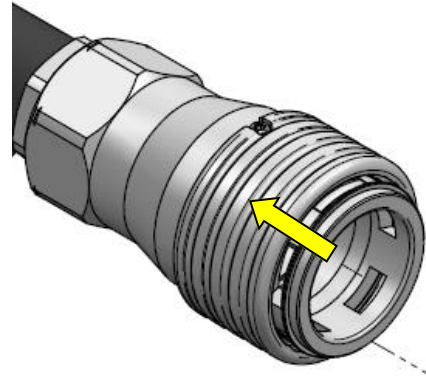

3. Remove dust cap from male fitting and push into female.

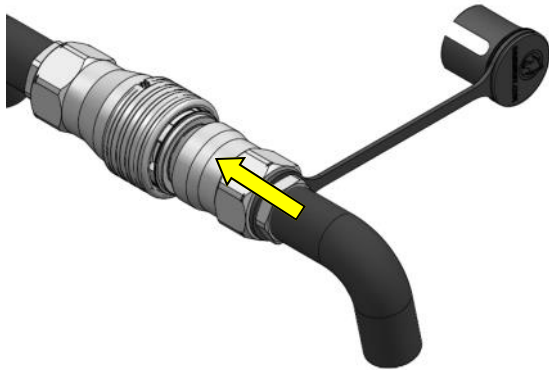

4. Sleeve should click forward into place.

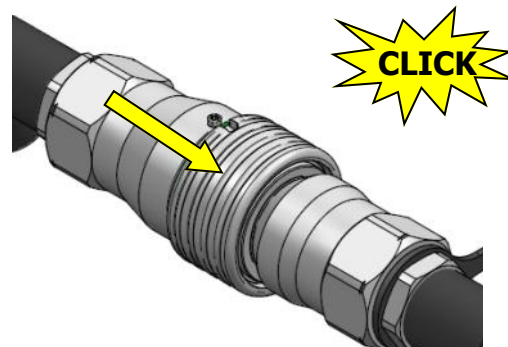

5. If successfully coupled, the green ring behind the sleeve will be visible. Twist the sleeve and check that coupling is locked in place.

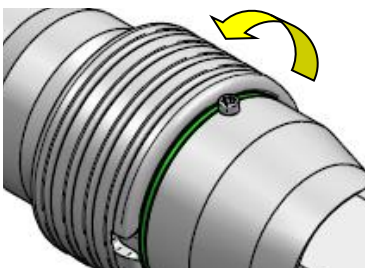

6. Apply pressure to begin using the Device.

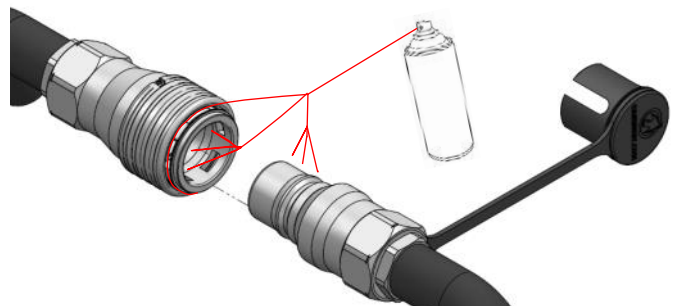

Oasis recommends the use of the following PPE when operating coupler.



Stand clear of coupler when in use. The use of hose restraints is recommended while using the HC308 couplers, contact Oasis Engineering for more info.



If coupler is hard to uncouple due to cold temperature icing, spray both male & female coupling faces with Interflon Fin Super (aerosol) or a similar product to help with ease of uncoupling in cold conditions.

1. Make sure the system is depressurized.



2. Align notch in sleeve with locating screw and pull back the sleeve.

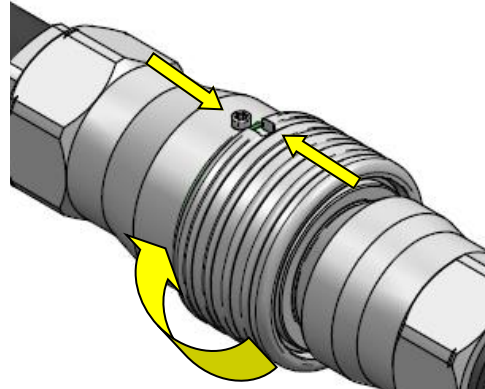

3. Pull out male fitting.

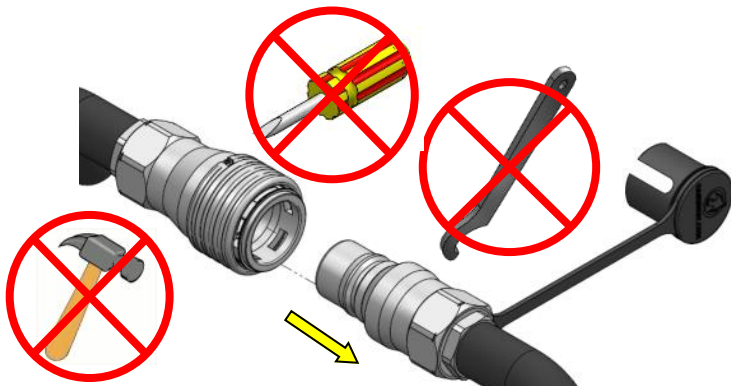

Do not use excessive impact or twisting force to separate coupler. For icing issues use HC308-COVER (sold separately)

4. Sleeve should return forward.

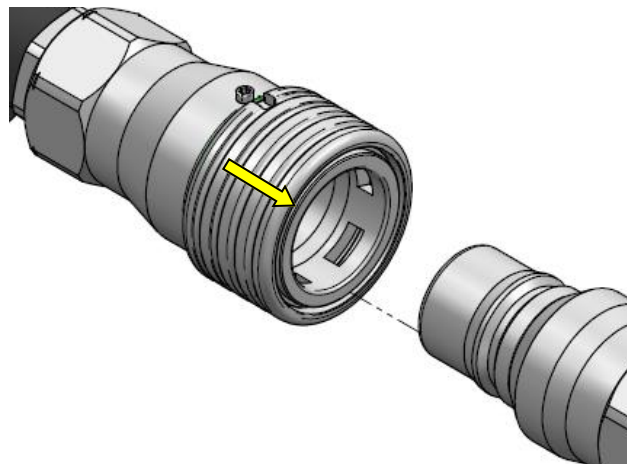

5. Put dust cap over male Fitting.



6. Return female fitting to a holder and always keep off the ground.

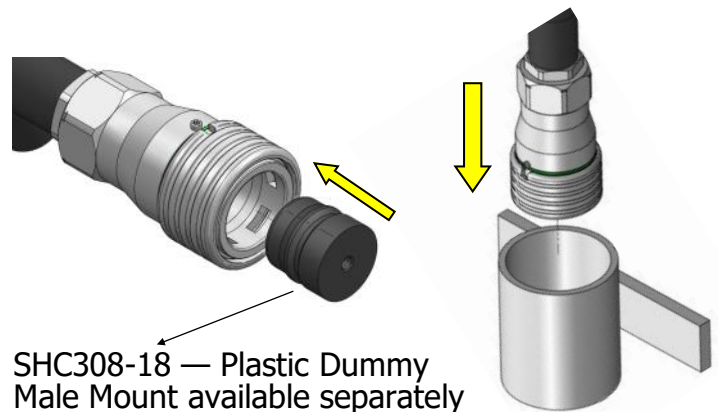

Service Kit Parts

Female Part



Poppet spring



Female poppet
(pre - assembled)



1x Backup



1x O-ring



Silicone Grease
Rocol MX22 or similar
(For all O-rings)



243 Loctite
medium strength

Male Part



Poppet spring



Male poppet
(pre - assembled)



Silicone Grease
Rocol MX22 or similar
(For all O-rings)



243 Loctite
medium strength

The Complete Oasis Seal Kit must be used

Tools Required



Cleaner (Warm Soapy
Water or Similar)

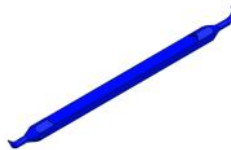

Pick Tool
Part Number:
TOOL-PICK
(Sold separately)



Anti Seize Grease
(Loctite 771 or Similar)
For All Threads

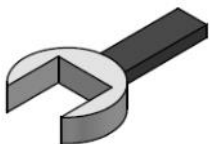

Spanner
(Wrenches)

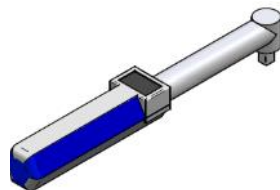

Torque Wrench

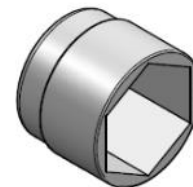

Sockets



Poppet Assembly tool
Part Number:
TOOL-HC308
(Sold separately)

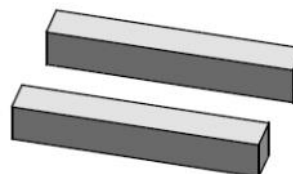

Vice

1. Clamp female coupler in vice.

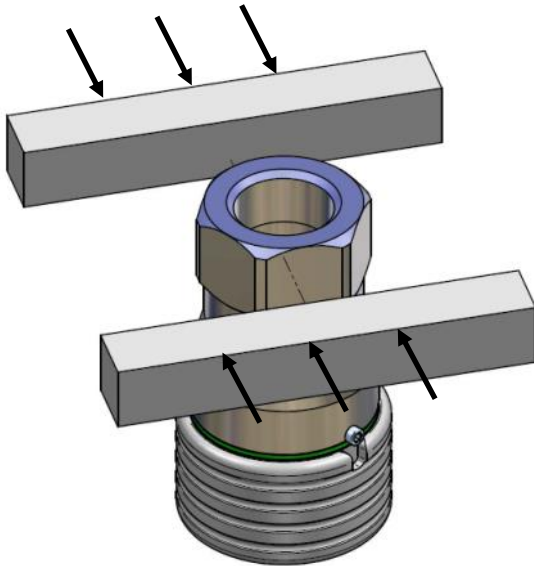

2. Position the assembly tool over the poppet retainer.

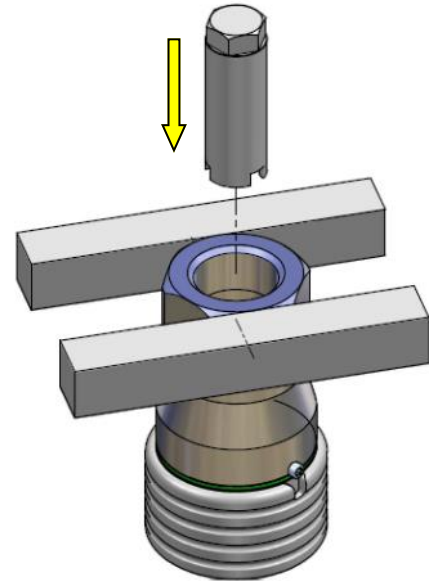

3. Remove the poppet retainer using the assembly tool.

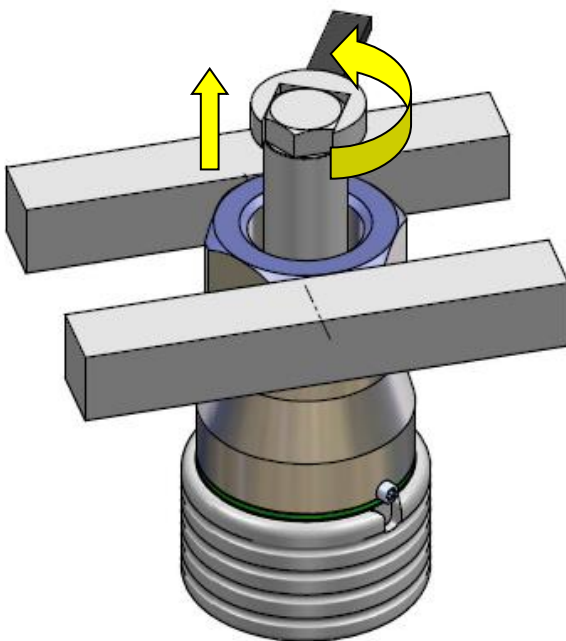

4. Lift out the poppet retainer and put aside.

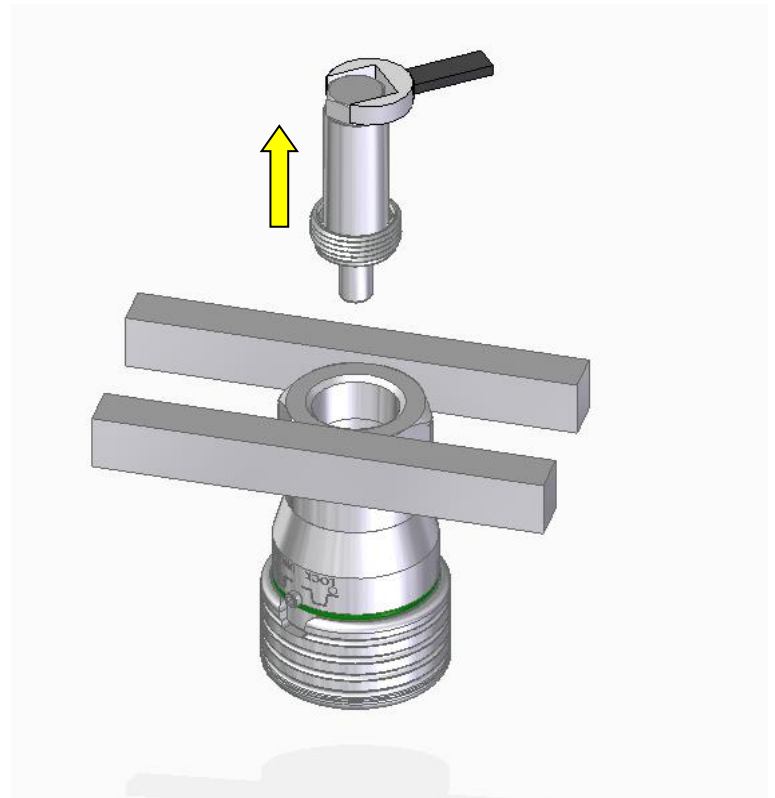

5. Discard the poppet and spring.

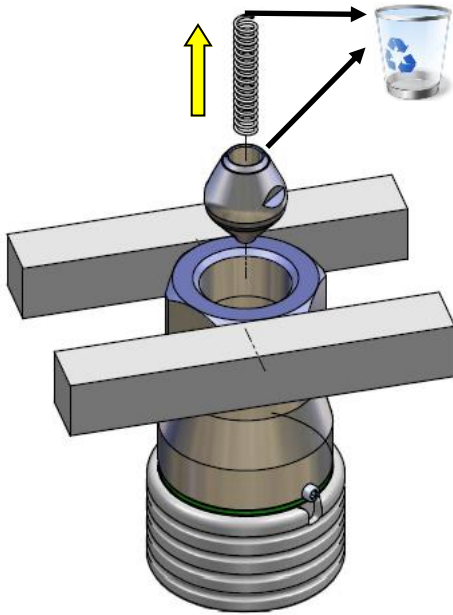

6. Pick out the O-ring and backup and discard.

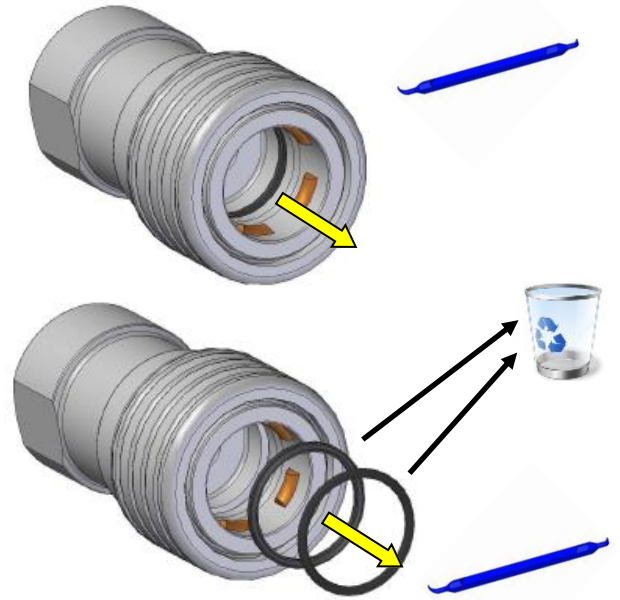

7. Clamp the male couple in the vice.

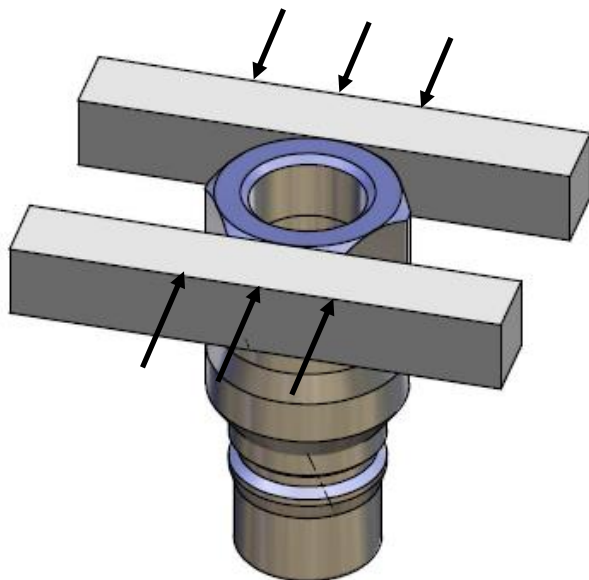

8. Position the assembly tool over the poppet retainer.

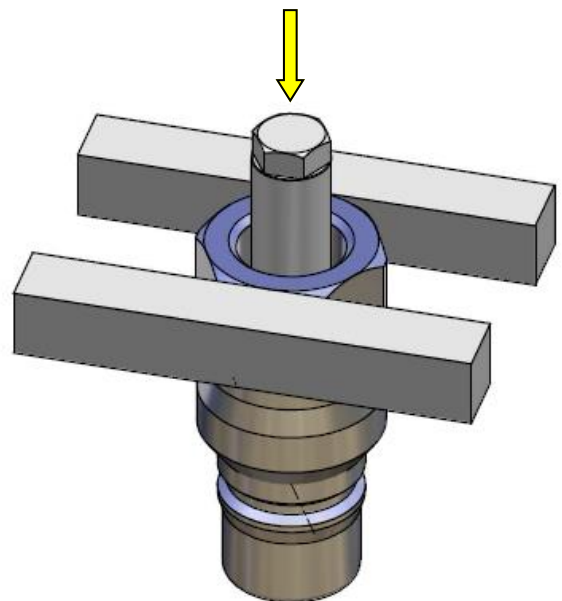

9. Remove the poppet retainer using the assembly tool.

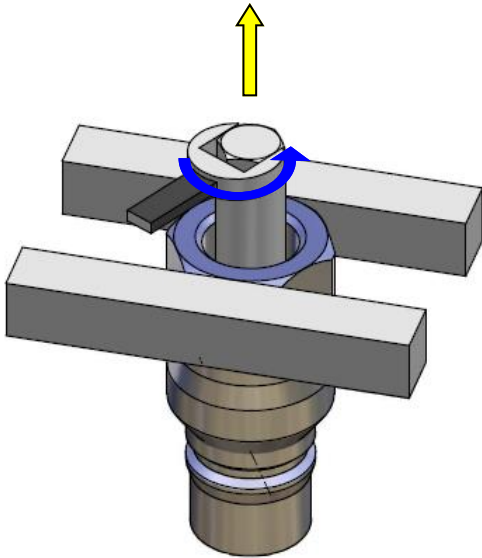

10. Remove the poppet retainer using the assembly tool.

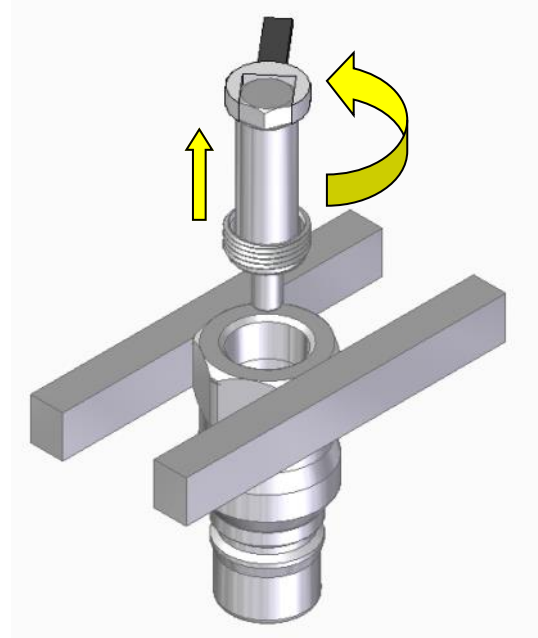

11. Discard the poppet and spring.

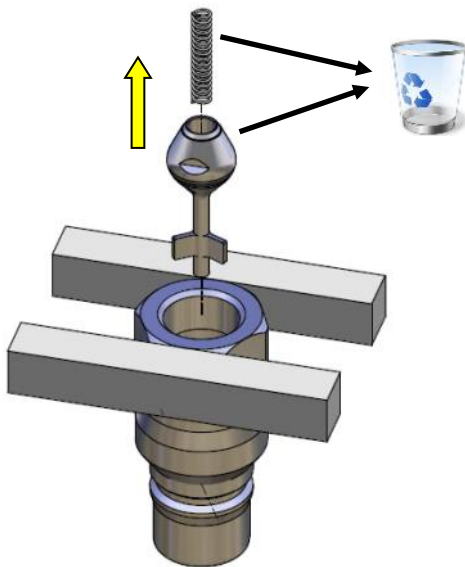

12. Clean all of the components and Visually Inspect parts for damage.

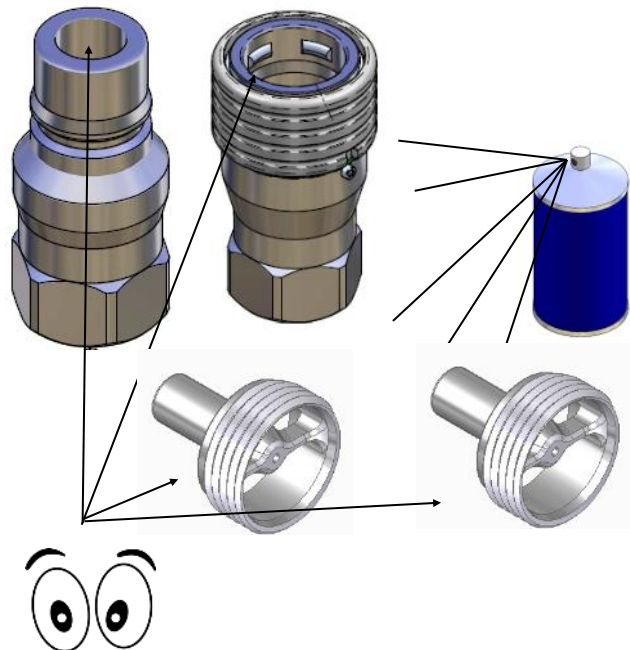

1. Apply Loctite in 2 places to the bottom 4 threads of the female body.

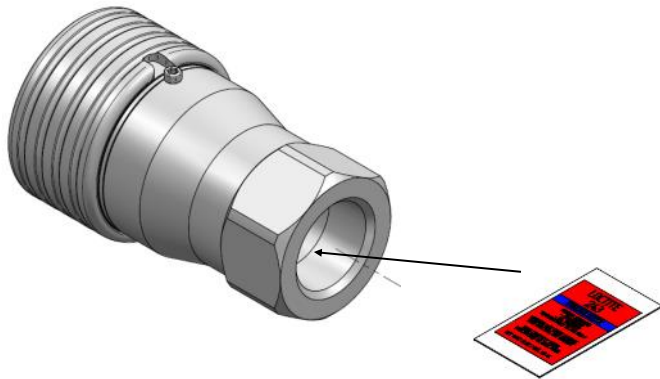

2. Holding the tool in a vice seat the poppet in the tool and screw the female body onto the poppet assembly. Be careful not to cross thread the retainer.

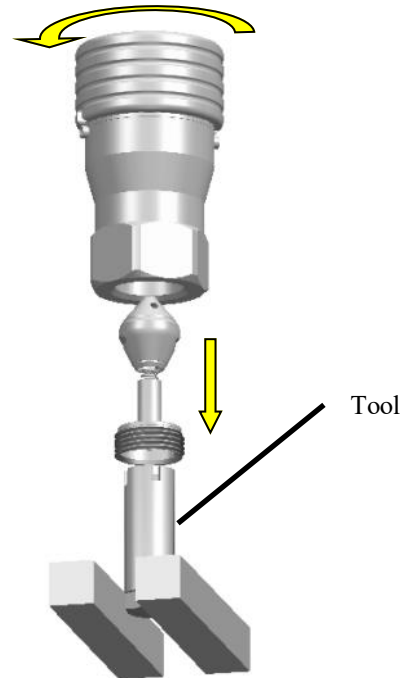

3. Torque the poppet retainer into the body.

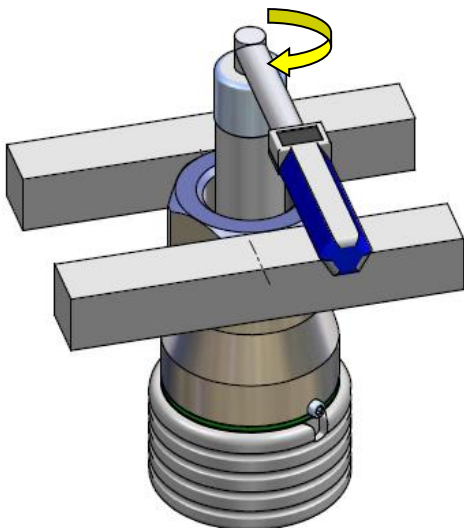

Recommended Torque :
40Nm

4. Insert the O-ring and back-up.

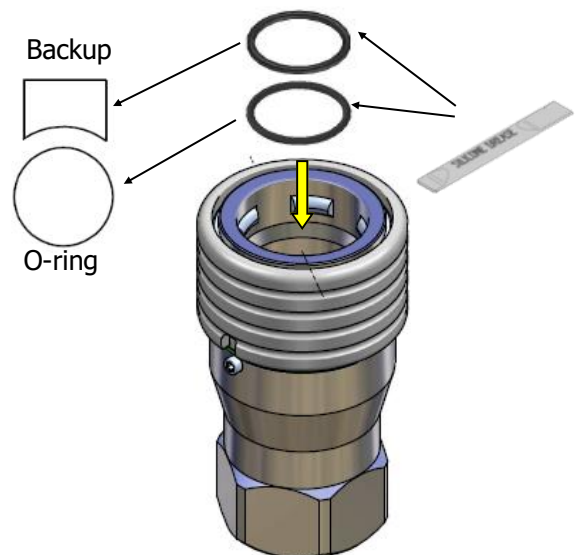

5. Check the poppet moves freely by pushing it and releasing it with your finger.



6. Servicing of the female is complete.



7. Apply Loctite in 2 places to the bottom 4 threads of the male body.

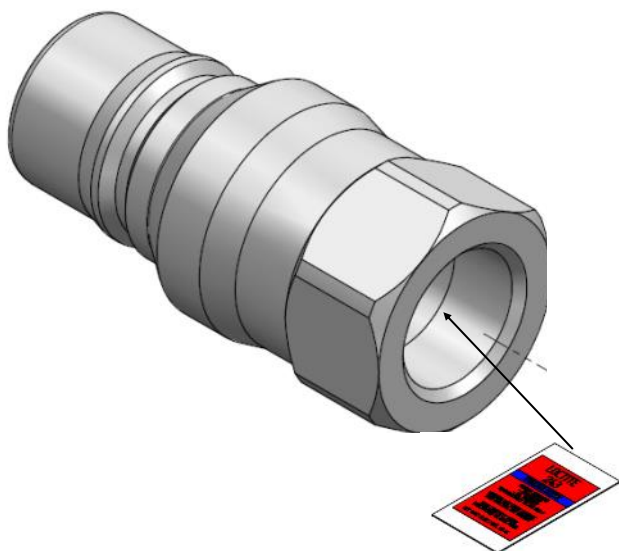

8. Holding the tool in a vice seat the poppet in the tool and screw the Male body onto the poppet assembly. Be careful not to cross thread the retainer.

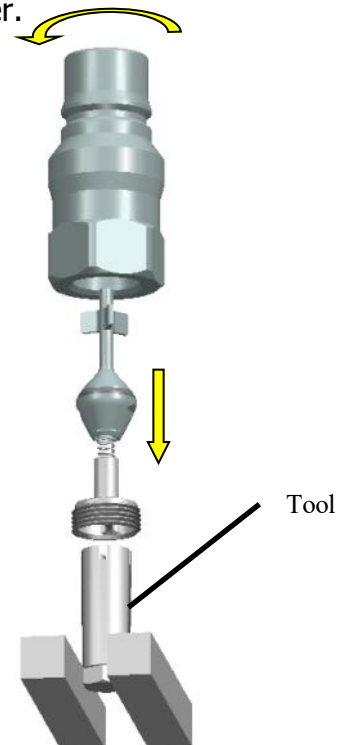

9. Torque the poppet retainer into the body.

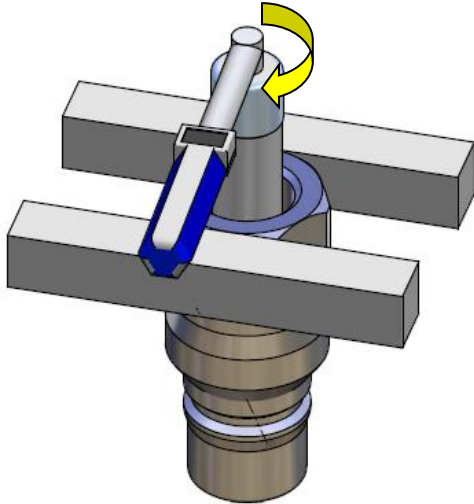

Recommended Torque :
40Nm

10. Check the poppet valve is free to move by depressing with a finger and allowing it to return.

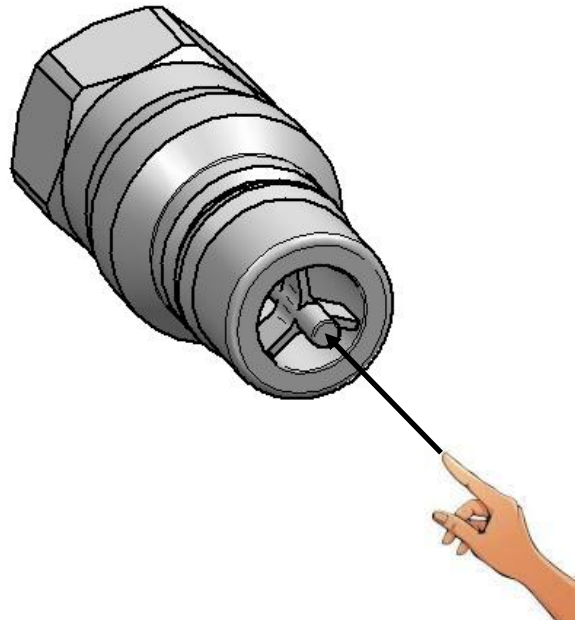

11. Coupler servicing complete. Ensure male and female fittings couple successfully and refer to installation instructions for refitting of the device and dust cap. It is recommended the product is checked for leaks on first use.

